



CUBICLE CURTAINS

Guide to Cubicle Curtain Fabrication

The following pages contain three distinctly different cubicle curtain fabrication methods. Each has its distinct advantages and disadvantages depending upon fabric chosen, facility type, and design parameters.

Standard Fabrication

Standard fabrication procedures use 72 inch and 54 inch wide fabrics. This method involves unrolling the fabric vertically, then cutting and sewing the fabric together in panels called widths. To conserve fabric (and cost) it is recommended that cubicle curtains fabricated using this method be made in increments of 3 feet wide.

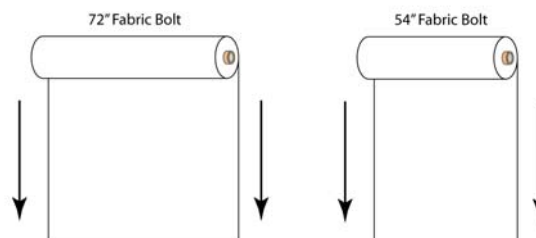

For example, in the picture below, a cubicle curtain that is 18 feet wide and is made from fabric that is 72 inches wide would be 3 widths wide. Make that curtain 3.5 widths wide and you now have a curtain that is 21 feet wide.

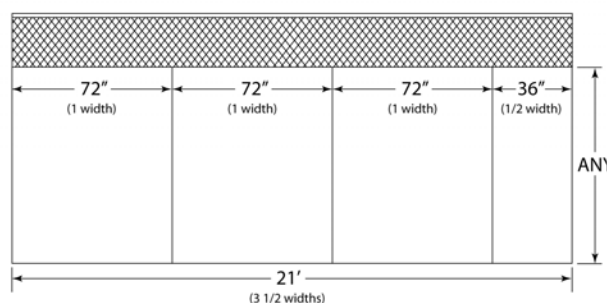
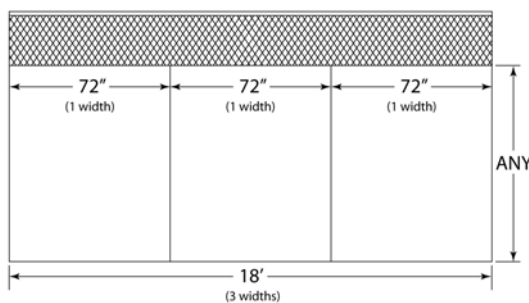

The same size cubicle made from a 54 inch wide fabric would have to be 4 widths wide to attain the same 18 foot width.

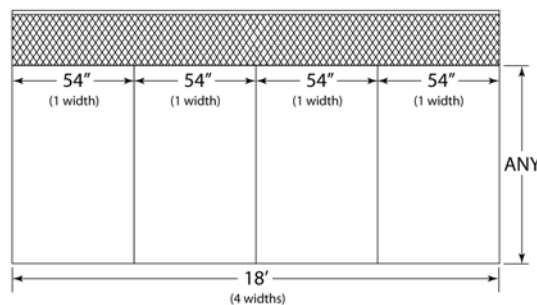

Add an extra 1/2 width and you add 27 inches (2 1/4 feet) to the width of the cubicle curtain making it a total of 20 1/4 feet wide as illustrated.

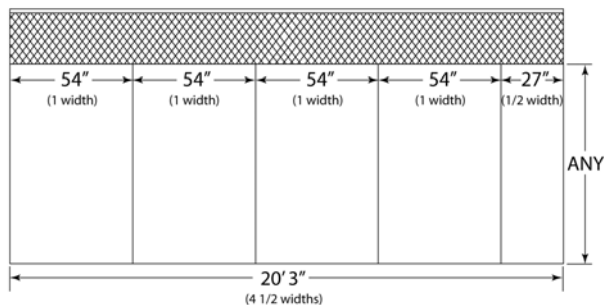



CUBICLE CURTAINS

Railroaded Fabrication

This method requires turning the bolt “sideways” and running it continuously with no seams. Railroaded cubicle curtains can be made to virtually any width, and are devoid of vertical seams.

However, unlike standard fabricated cubicles, railroaded cubicles are limited in length. A railroaded cubicle curtain made with a 72 inch fabric is limited in length to 68 inches, unless mesh is added, at which point the length can be extended up to 90 inches.

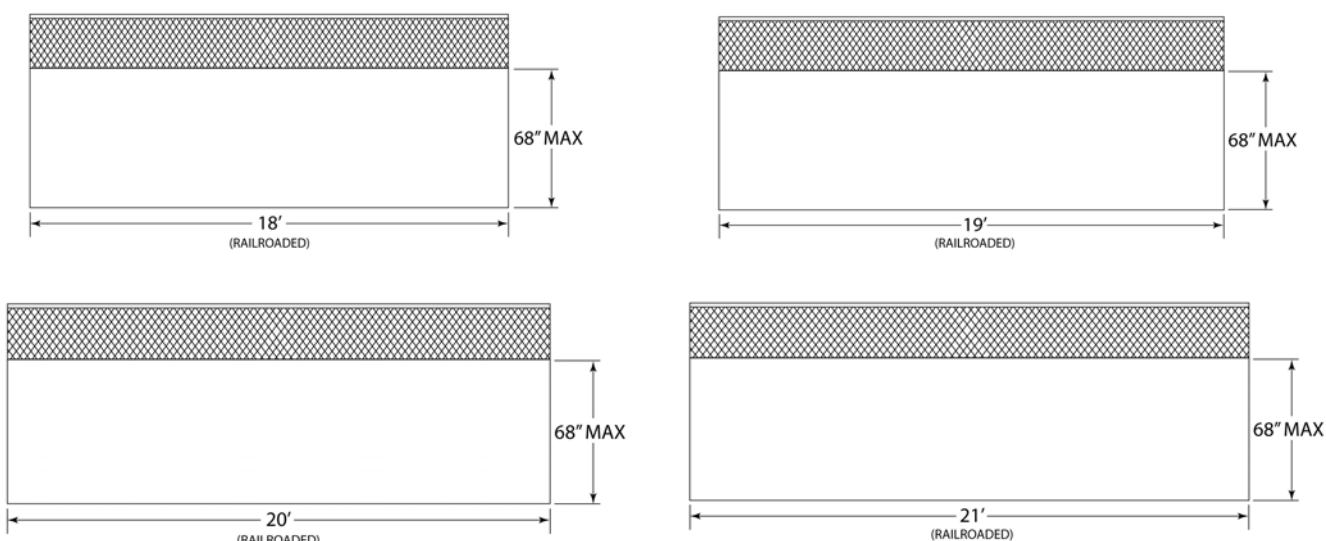
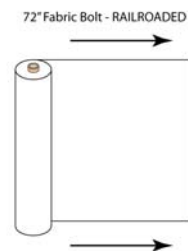

Due to different pattern designs, you may notice that a memo sample is marked “Shown Railroaded”. To preserve the pattern the way it is shown, the cubicle curtain (or drapery) must be sewn railroaded and the above mentioned height limitations adhered to.

Choo-Choo Fabrication

This fabrication method necessitates making the cubicle curtains all the same size as panels. The grommets in the top of each panel are unique- most cubicle curtains have the grommets spaced every 6 inches on center.

A Choo-Choo’ed cubicle curtain has the grommets spaced 4 inches apart on each end with 6 inch spacing for the grommets in the center, as illustrated below.

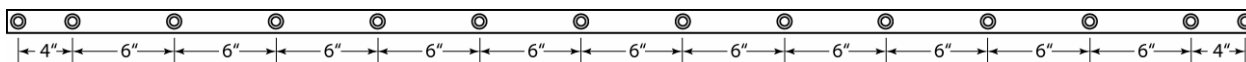



CUBICLE CURTAINS

Choo-Choo Fabrication (cont.)

When installed, the cubicles are overlapped on each end by 4 inches. Depending upon track length, panels can be added indefinitely.

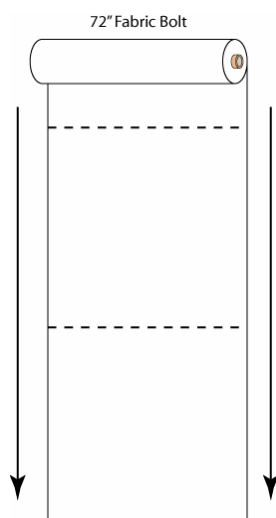
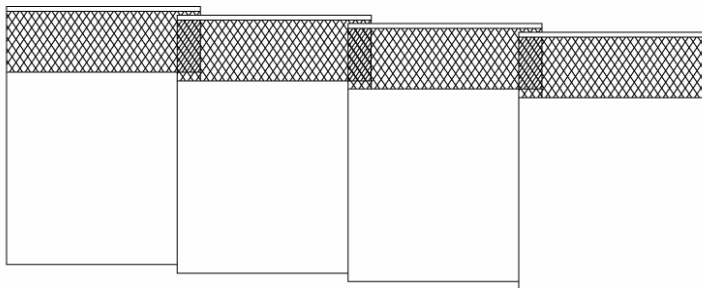

While any fabric can be made into a Choo-Choo configuration, this method must be used for specialty fabrics that are designed as panels. These fabrics typically are 72" wide, and are designed to be cut off the roll every 50 to 80 inches. Due to the horizontal repeat of these specialized fabrics, standard cubicle fabrication is oftentimes not an option. Also, like railroaded fabric, panel fabrics (when made from specialized panel style fabrics) are limited in length. Mesh can be used to extend this total length by 18 to 30 inches.

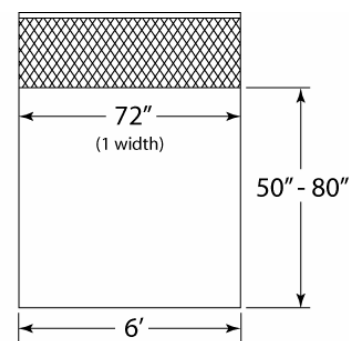

The advantage of this method is the one size, multiple curtain layout- when a longer track requires a wider cubicle, you simply add the necessary panels. If one panel gets soiled, remove and replace with another panel. It saves facilities time as they do not have to stock a wide variety of different cubicle sizes to meet all of their different length tracks. The disadvantages of this method are cost, possible privacy issues, and aesthetics. A Choo-Choo'ed cubicle curtain costs more than conventional cubicles as it requires more fabric (due to the 4 inch overlap at the edge of each panel). This overlap, where the panels meet, may also present a privacy issue if the natural lay of the curtain is obstructed by carts, tables, beds, or other equipment.



CUBICLE CURTAINS

Guide to Cubicle Curtain Options

The options outlined below show Diamond Drapery's versatility when it comes to making custom cubicle curtains for any customer, application, or design. Cubicle curtains are a major aspect of any patient room or area in a healthcare facility. Taking the time to fabricate in some design options can create a beautiful and functional centerpiece for many years to come.

Self-Framing

For cubicle curtains with mesh only, this option provides a 1 ½ inch fabric boarder sewn around the top of the cubicle curtain. Depending upon the size of the repeats in the fabric used, the pattern in the framed edge may not exactly line up with the repeats in the main body of the cubicle.

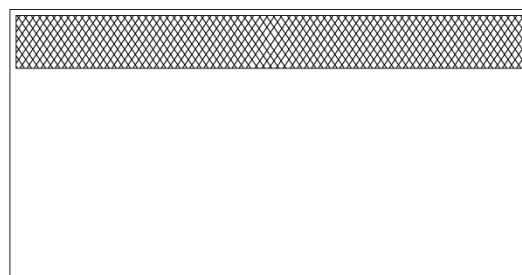

Break-Away Tops

Break-away systems are designed for use in mental health areas or where there is a risk of the patient harming themselves by becoming entangled in the cubicle curtain. In this situation, hook and loop is sewn along the top of the curtain, and hook and loop tabbed carriers are used to attach it to the tracking system. If requested, snaps are pressed into the ends of the cubicle and two (2) special snap carriers are provided.

Colored Mesh

Several different colors of mesh are available in sizes ranging from 12 to 36 inches long. Sizes vary depending upon color- check with Diamond Drapery, or visit www.diamonddrapery.com, for a current list of available sizes and colors.

Cut Outs

Special areas require custom made cubicle curtains. In tiered areas or in situations where a low partition counter may separate two patient beds, a custom cut out can provide the solution.

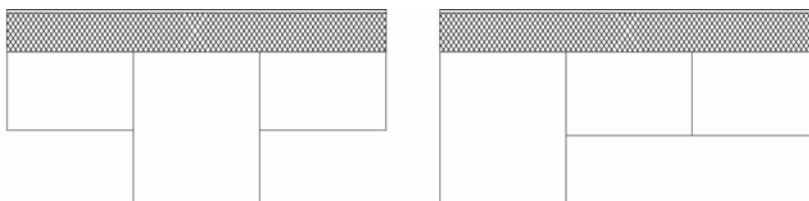

Specialty Options

Each and every cubicle curtain is custom made per each order and over the past 35 years, we have seen just about everything when it comes to custom, customer specific cubicle curtains. If you don't see it listed here, give us a call and talk to one of our customer service representatives.