

CUBICLE TRACKING ASSEMBLY INSTRUCTIONS

5000 SERIES

Ceiling Mounted

Cut track to length and attach end stops (use End Stops in pairs: one with a pull-out, and one without). Secure track to ceiling or wall (see installation instructions). Once track is securely mounted, remove pull-out from end stop, insert the required number of carriers, and reinsert pull-out into the end stop. To install the cubicle curtain, carefully slide the grommets, located at the top of the cubicle curtain, over the hooks of the carriers.

For smoother operation, lightly spray the inside of the track with an aerosol silicone lubricant. Depending upon environment, clean and re-lubricate as necessary.

Suspension Mounted

Cut track to length and attach end stops (use End Stops in pairs: one with a pull-out, and one without). If either of the track ends will be butting directly into a wall, replace the necessary End Stop(s) with a Track End Wall Bracket as shown in Option #2 above. For details, refer to Track End Wall Bracket assembly instructions. Attach suspension tubing ceiling brackets to the ceiling (see installation instructions) then attach suspension tubing and track brackets. Position suspension tubing assemblies along path of the track at 24" to 36" intervals. Once the suspension tubing is securely mounted to the ceiling, attach the track to the suspension tubing. Refer to the Suspension Mount Radius Connector and Suspension Mount Wall Bracket assembly instructions for additional assembly details. Once the track is secured, remove pull-out from end stop, insert the required number of carriers, and re-insert pull-out into the end stop. To install the cubicle curtain, carefully slide the grommets, located at the top of the cubicle curtain, over the hooks of the carriers.

For smoother operation, lightly spray the inside of the track with an aerosol silicone lubricant. Depending upon environment, clean and re-lubricate as necessary.

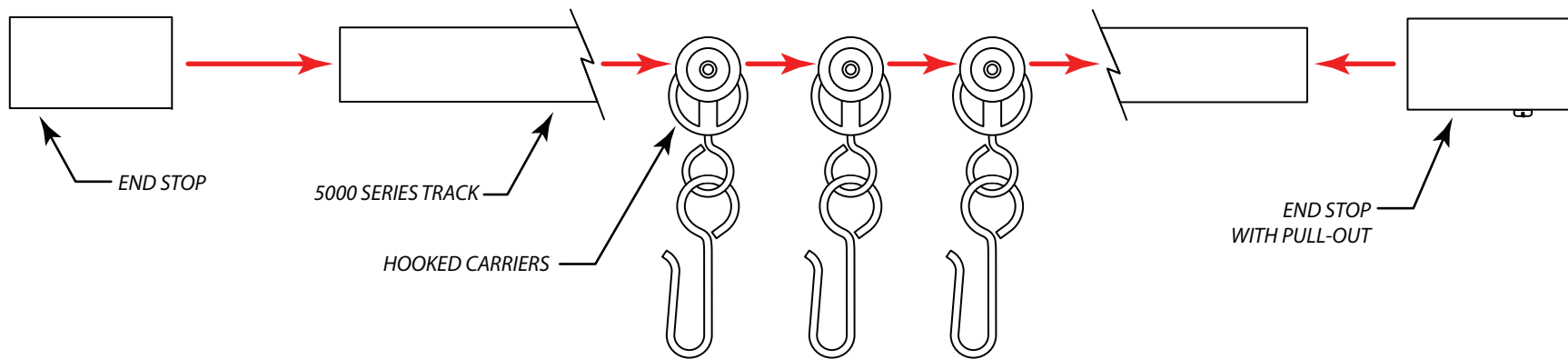

<p>CONFIDENTIAL All materials disclosed in this document are proprietary to Diamond Drapery Co., Inc. The Holder agrees to maintain it in confidence and must not replicate or reveal this information in any manner.</p>	<p>Project: 5000 Series Tracking System Assembly</p>	
	<p>Date: 16-DEC-2008</p>	<p>Dimensions: Inches/Feet</p>
	<p>Scale: DO NOT SCALE</p>	<p>By: C. Johnson</p>



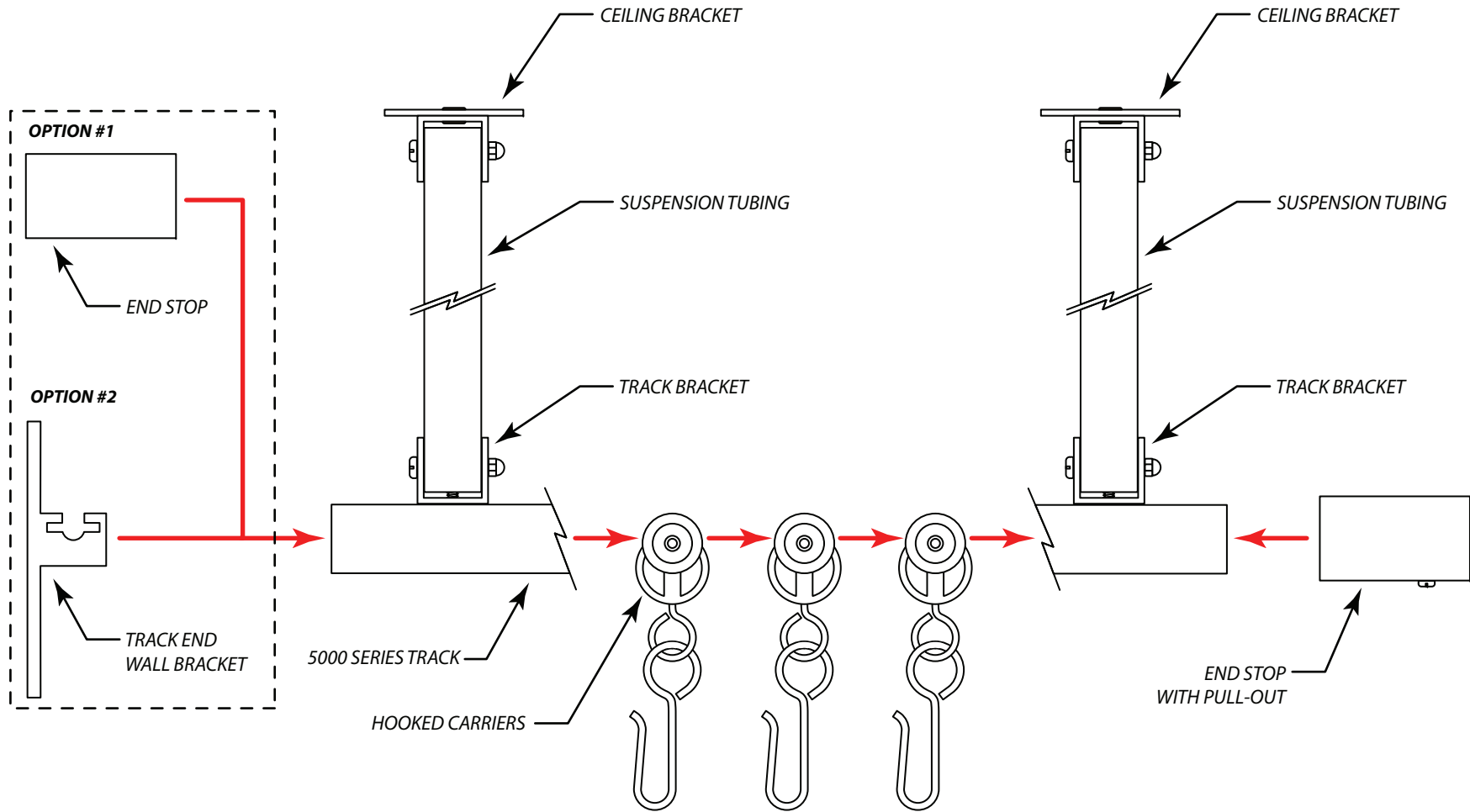

CONFIDENTIAL All materials disclosed in this document are proprietary to Diamond Drapery Co., Inc. The Holder agrees to maintain it in confidence and must not replicate or reveal this information in any manner.	Project: 5000 Series Suspended Tracking System Assembly	
	Date: 16-DEC-2008	Dimensions: Inches/Feet
	Scale: DO NOT SCALE	By: C. Johnson



7439 Lampson Avenue
 Garden Grove, CA 92841
 (714) 761-4543 OFFICE (714) 761-4623 FAX

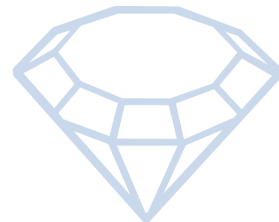

CUBICLE TRACKING ASSEMBLY INSTRUCTIONS

5000 SERIES CUBICLE TRACK – SUSPENSION MOUNT RADIUS CONNECTOR

A radius connector (part #5000-17) is used to attach the end of a suspension mounted track to the bend (radius) of another track. By tying the track configurations together, this bracket greatly enhances the integrity of a suspension mounted cubicle tracking system and is virtually required when many configurations are ganged together, as illustrated below.

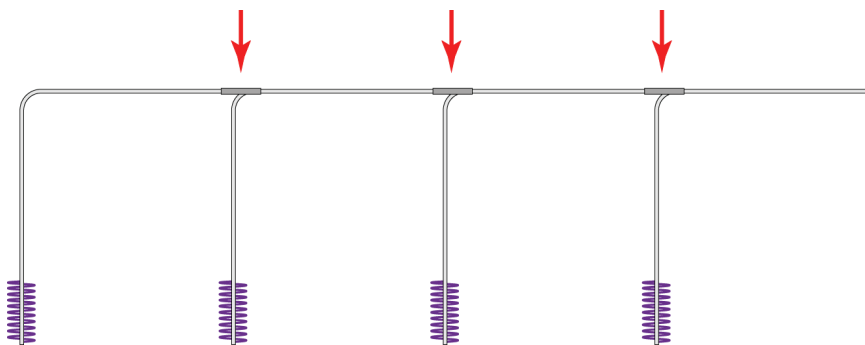
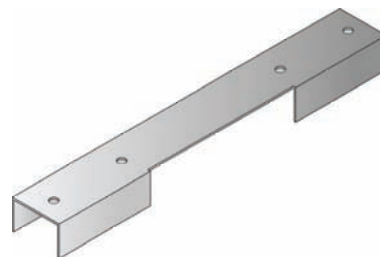

Instructions:

1. Once the first suspended track system is in place, layout of the second track begins. At this time, connect the tracks using the radius connector. Slide the radius connector over the end of the first track and over the bend (radius) of the second track. Note the positioning of the tracks in radius connector. Typically End Stops cannot be used with a radius connector. When this is the case, use a self-tapping metal screw inserted $\frac{1}{2}$ " from the end of the first track as the carrier stop. Leave this screw just flush with the bottom of the track to allow it to effectively stop the carriers.

TOP VIEW

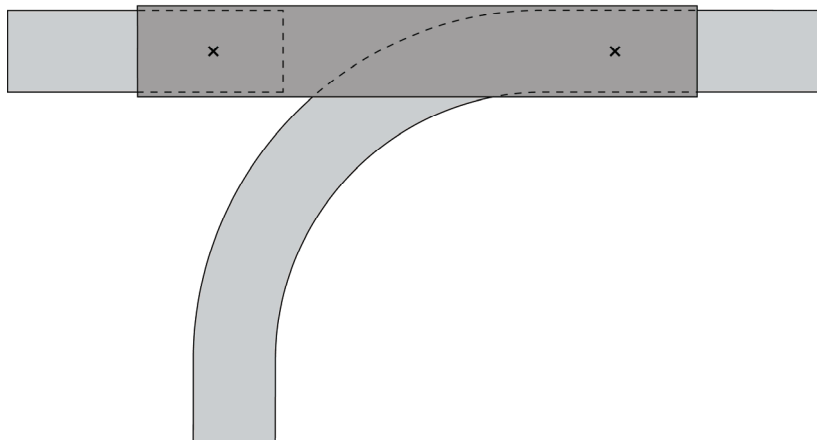

2. Upon final positioning of the second track system, secure the radius connector into place by running two screws up from the bottom of the track, through the top of the radius connector.

SIDE VIEW



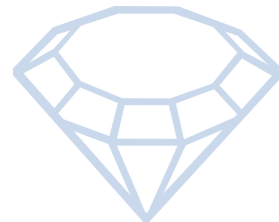

CUBICLE TRACKING ASSEMBLY INSTRUCTIONS

5000 SERIES CUBICLE TRACK – TRACK END WALL BRACKET

A Track End Wall Bracket (part #5000-07) is used to attach the ends of suspension mounted tracks to the wall and acts as a closed end stop. This mounting greatly enhances the integrity of a suspension mounted cubicle tracking system.

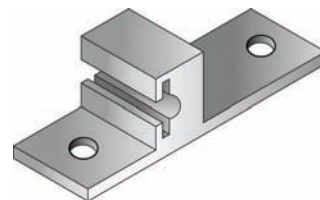

Instructions:

3. Once the suspended track system is in place, locate the track ends and mark their position on the wall. Loosen the track and swing it out of the way. Measure and attach the Wall Bracket to the wall using the appropriate mounting method (drywall & stud method illustrated here).

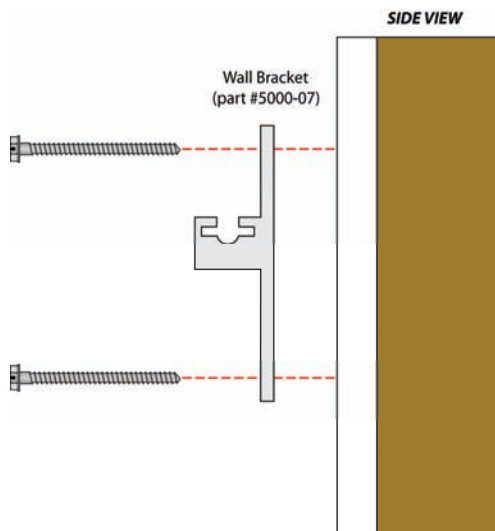

4. Slide the end of the track over the Wall Bracket.

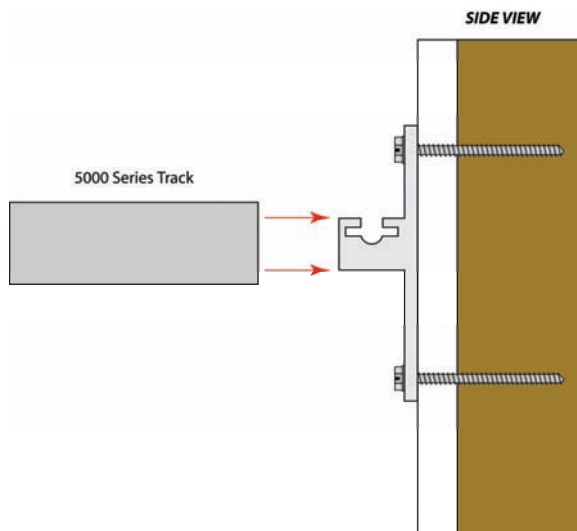

5. Secure track to the Wall Bracket using a self-tapping screw. Run the screw through the side of the track and through the slot in the Wall Bracket.

